

# HXG20

## Facts and Data

### Digital Monochrome Matrix Camera, 2 Megapixel, Dual GigE

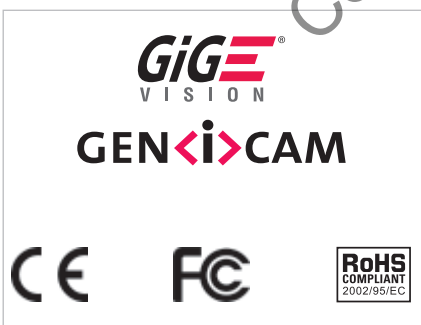
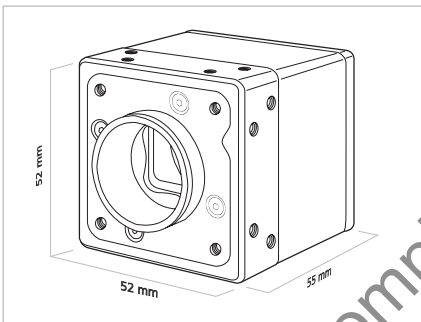

Baumer Optronic GmbH  
 Badstrasse 30  
 DE-01454 Radeberg, Germany  
 Phone +49 (0)3528 4386 0  
 Fax +49 (0)3528 4386 86  
 sales@baumeroptronic.com  
 www.baumer.com/cameras

#### Sensor Information

Model Name	CMOSIS CMV-2000
Type	2/3" progressive scan CMOS
Native Resolution	2048 × 1088 pixels
Exposure Time	20 µsec ... 1 sec

#### Acquisition Formats

Image Formats	Full Frame	2048 × 1088 pixels	max. 105 fps
Pixel Formats	Mono8, Mono10, Mono12		
Partial Scan	True Partial Scan, Region of Interest (ROI) arbitrary		

#### Image Pre-processing

Analog Controls	Gain (0 ... 12 dB), Offset (0 ... 255 LSB)
Color Modes	Mono

#### Camera Features

Internal Buffer	256 MBytes (max. 110 images)
Synchronization	Free running, Trigger
Trigger Sources	Hardware, Software, Action Command
Trigger Delay	0 ... 2 sec, Tracking and buffering of up to 512 trigger signals
Digital I/Os	3 input lines (with Debouncer), 3 output lines

#### Interfaces and Connectors

Data Interface	Dual GigE, Transfer Rate 2000 Mbit/sec Connector: 8P8C Modular Jack (RJ45), screw lock type
Process Interface	M8 / 8 pins
Power Interface	M8 / 3 pins

#### Mechanical Data

Housing	Aluminum, IP40
Lens Mount	C-Mount
Dimensions	52 x 52 x 55 mm <sup>3</sup>
Weight	210 g (C-Mount)

#### Electrical Data

Power Supply	20 ... 30 V DC
Power Consumption	approx. 8 Watt (with camera factory settings)

#### Environmental Data

Operating Temperature	+5 °C ... +50 °C (+41 °F ... +122 °F)
Humidity	10% ... 90% non condensing