

SXG20

Facts and Data

Digital Monochrome Matrix Camera, 2 Megapixel, Dual GigE

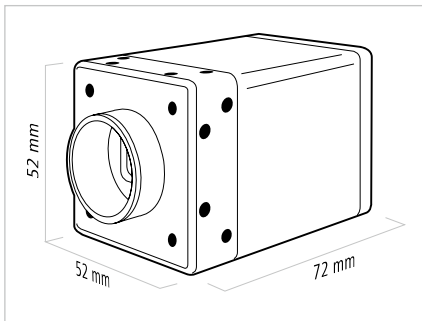

GIGE[®]
VISION
GEN<i>i>CAM



Baumer Optronic GmbH
Badstrasse 30
DE-01454 Radeberg, Germany
Phone +49 (0)3528 4386 0
Fax +49 (0)3528 4386 86
sales@baumeroptronic.com
www.baumer.com/cameras

Sensor Information

Model Name	Truesense Imaging KAI-02050
Type	2/3" interline progressive scan CCD
Native Resolution	1600 × 1200 pixels
Exposure Time	10 µsec ... 1 sec

Acquisition Formats

Image Formats	Full Frame	1600 × 1200 pixels	max. 68.0 fps
	Binning 2x2	800 × 600 pixels	max. 123.0 fps
	Binning 1x2	1600 × 600 pixels	max. 123.0 fps
	Binning 2x1	800 × 1200 pixels	max. 68.0 fps
Pixel Formats	Mono8, Mono10, Mono12		
Partial Scan	True Partial Scan, Region of Interest (ROI) arbitrary		

Image Pre-processing

Analog Controls	Gain (0 ... 26 dB), Offset (0 ... 1023 LSB 14 bit)
Color Modes	Mono

Camera Features

Internal Buffer	256 MBytes (max. 120 images)
Synchronization	Free running, Trigger
Trigger Sources	Hardware, Software, Action Command
Trigger Delay	0 ... 2 sec, Tracking and buffering of up to 512 trigger signals
Digital I/Os	3 input lines (with Debouncer), 3 output lines

Interfaces and Connectors

Data Interface	Dual GigE, Transfer rate 2000 Mbit/sec Connector: 8P8C Modular Jack (RJ45), screw lock type
Process Interface	M8 / 8 pins
Power Interface	M8 / 3 pins

Mechanical Data

Housing	Aluminum, IP40
Lens Mount	C-Mount
Dimensions	52 × 52 × 72 mm ³
Weight	285 g

Electrical Data

Power Supply	20 ... 30 V DC
Power Consumption	approx. 11 Watts

Environmental Data

Operating Temperature	+5 °C ... +60 °C (+41 °F ... +131 °F)
Humidity	10% ... 90% non condensing