



## Machine Vision Camera Enclosure IP67 29mm Series Square

As a leading innovator in the Machine Vision Industry, CEI is proud to introduce our new line of Machine Vision Camera Enclosures, Cables, and Accessories for demanding vision applications.

### IP67 29mm Series Camera Enclosure Key Features

- CEI Integrated Connector Design ( no cord grips )
- IP67 protection
- Universal design for popular 29mm camera models
- Excellent heat dissipation
- Enclosure tailored for specific Camera & Optics
- Flexible mounting options
- High quality (easy to replace) windows by Midwest Optics
- Lightweight low-profile design
- Type 2 anodizing
- Options: Mounts, Visors, Air Curtains, Windows & Filters, Cables
- Options: Custom Sizes, lengths, and focusing solutions.
- Options: Complete Solutions (Camera, Enclosure, Cabling)
- Competitive pricing
- Made in USA , Patent Pending

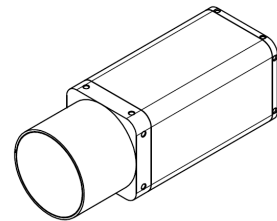

### Enclosure Specs (See Appendix "A" for part numbers)

*Camera:* 29mm square mount machine vision

*Optics:* Supports a wide range of C-Mount optics

*Window:* Midwest Optical 2mm Borofloat glass – AR coated

*Interface Connector:* M12 X-Code Ethernet

*Optional Interface:* M12 A-Code I/O Male

*Mounting:* M3 tapped holes / 1/4"-20 with optional adapter

*Sealing:* IP67

*Material:* 6063 Aluminum

*Coating:* Type 2 anodized

*Length:* 143 mm (with 38mm Lens Cover and M12 connector.)

*Height / Width:* 44.5 mm square

*Window Diameter:* 42 mm

*Weight:* 355 g (typical weight fully assembled W/ Camera)

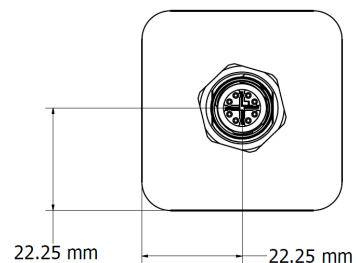
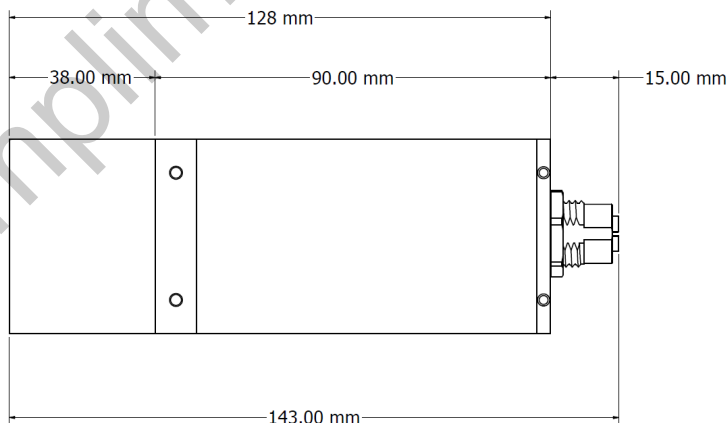
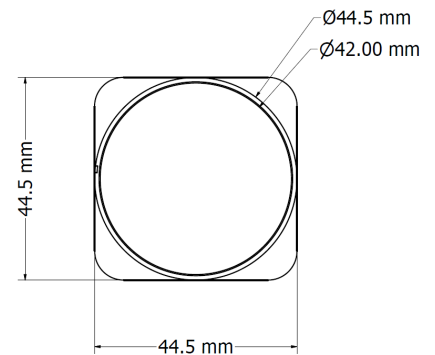

## Appendix "A" CEI IP67 29mm Series Camera Square:

CEI "Small" square 29mm IP67 Gig-E Enclosure for up to 38mm dia. C-mount lenses, M12 Gig-E connector, and 2x M3 tapped mounting holes.

<u>Part Number</u>	<u>Description (enclosure &amp; mount only, lens cover required - see below)</u>
<b>EN-29S-38</b>	29mm Square IP67 enclosure, 38mm max. lens dia., M3 mount holes

CEI "Small" square 29mm IP67 Enclosure for up to 38mm dia. C-mount lenses with M12 Gig-E and I/O connectors, and 2x M3 tapped mounting holes.

<u>Part Number</u>	<u>Description (enclosure &amp; mount only, lens cover required see below)</u>
<b>EN-29SI-38</b>	29mm Square IP67 enclosure, 38mm max. lens dia., M3 mount holes

Lens Covers with 2mm Borofloat AR coated glass windows for CEI EM-29S series IP67 enclosures

<u>Part Number</u>	<u>Description (lens cover only, enclosure required - see above)</u>
--------------------	--

<b>EN-LC38-30</b>	38mm max. lens dia., 30mm length
<b>EN-LC38-36</b>	38mm max. lens dia., 36mm length
<b>EN-LC38-38</b>	38mm max. lens dia., 38mm length
<b>EN-LC38-44</b>	38mm max. lens dia., 44mm length
<b>EN-LC38-48</b>	38mm max. lens dia., 48mm length
<b>EN-LC38-50</b>	38mm max. lens dia., 50mm length
<b>EN-LC38-52</b>	38mm max. lens dia., 52mm length

Assembled lens cover dimension is 6mm shorter than specified lens cover length, for example a EN-29S-30 enclosure assembly with EN-LC38-36 lens cover will be  $90\text{mm} + 36\text{mm} - 6\text{mm} = 120\text{mm}$  long (L)

Optional accessories for CEI square 29mm IP67 Enclosure

<u>Part Number</u>	<u>Description</u>
<b>EN-2X.25-20-BRK</b>	1/4-20 mount adapter for CEI 29mm square IP67 enclosure