



CEI Machine Vision Camera Enclosure Stainless Series

As a leading innovator in the Machine Vision Industry, CEI is proud to introduce our new line of Machine Vision Camera Enclosures, Cables, and Accessories for demanding vision applications.

CEI Camera Enclosure Key Features

- CEI Integrated Connector Design (no cord grips)
- IP69K protection
- Excellent heat dissipation
- Enclosure tailored for specific Camera & Optics
- Flexible mounting options
- High quality (easy to replace) windows by MidOpt
- Round wash-down design
- All Stainless Steel construction
- Options: Mounts, Visors, Air Curtains, Windows & Filters
- Options: Cables , Custom Sizes, lengths, and focusing solutions.
- Options: Complete Solutions (Camera, Enclosure, Cabling)
- Competitive pricing
- Made in USA

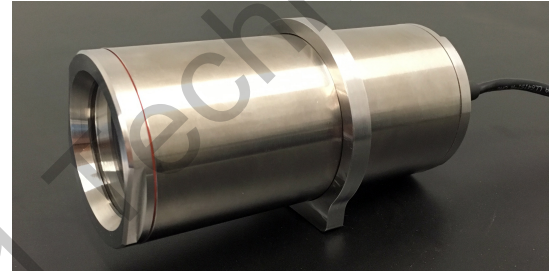

Enclosure Specs (CEI Stainless Series)

Application: Food and Beverage applications

Camera: Popular Gig-E Machine Vision Cameras

Window: LP8000 Germanium DLC Coated LWIR Protective Window

Interface Connector: RJ45 Male IP69K CEI MV-4 profile

Mounting: 1/4 - 20 UNC tapped hole x 2

Sealing: IP69K

Material: Stainless Steel – 304 grade

Length: 6.6 Inches

Diameter: 3 Inches

Window Diameter: 2.2 Inches

Weight: 5.2 Lbs. (without camera & optics)

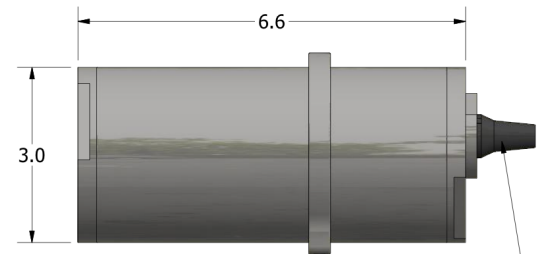
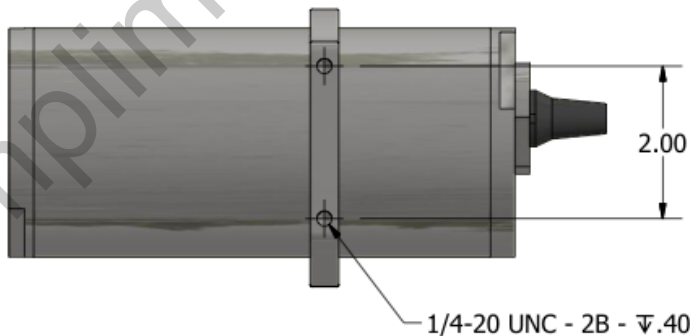
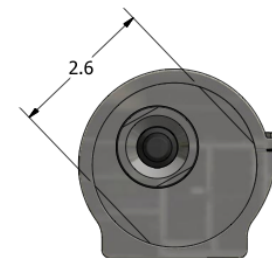
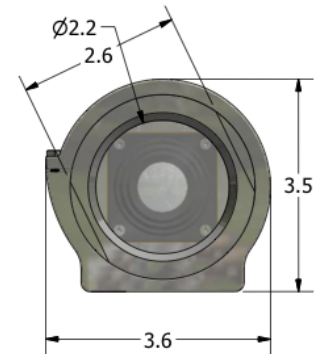

**RJ45 Male IP69K
CEI MV-4 Profile**

Call Components Express, Inc. at 630-257-0605 for Ordering Information.