



COMPONENTS EXPRESS, INC.
INDUSTRY LEADING PERFORMANCE

10330 Argonne Woods Drive, Suite 100 • Woodridge, IL 60517

Tel 630-257-0605 / 800-578-6695 (outside Illinois) Fax 630-257-0603

CEI Machine Vision Camera Enclosure Stainless Series

As a leading innovator in the Machine Vision Industry, CEI is proud to introduce our new line of Machine Vision Camera Enclosures, Cables, and Accessories for demanding vision applications.

CEI Camera Enclosure Key Features

- CEI Integrated Connector Design (no cord grips)
- IP67 protection
- Excellent heat dissipation
- Enclosure tailored for specific Camera & Optics
- Flexible mounting options
- High quality (easy to replace) windows by MidOpt
- Round wash-down design
- All Stainless Steel construction
- Options: Mounts, Visors, Air Curtains, Windows & Filters
- Options: Cables , Custom Sizes, lengths, and focusing solutions.
- Options: Complete Solutions (Camera, Enclosure, Cabling)
- Competitive pricing
- Made in USA

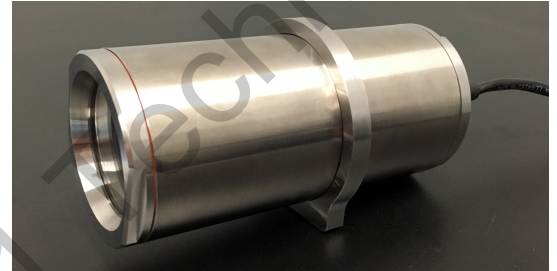

Enclosure Specs (CEI Stainless Series)

Application: Food and Beverage applications

Camera: Popular Gig-E Machine Vision Cameras

Window: MIDOPT 3mm Polycarbonate – AR coated

Interface Connector: RJ45 Male IP67 CEI MV-4 profile

Mounting: 1/4 - 20 UNC tapped hole x 2

Sealing: IP67

Material: Stainless Steel – 304 grade

Length: 6.6 Inches

Diameter: 3 Inches

Window Diameter: 2.2 Inches

Weight: 5.2 Lbs. (without camera & optics)

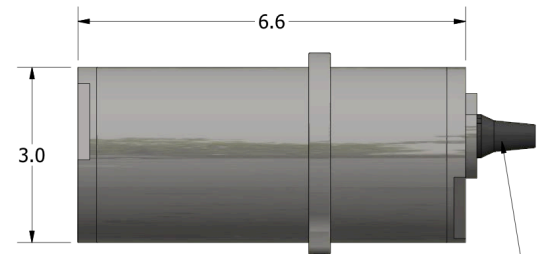
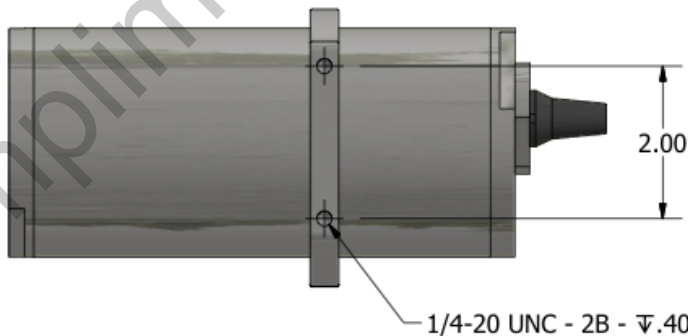
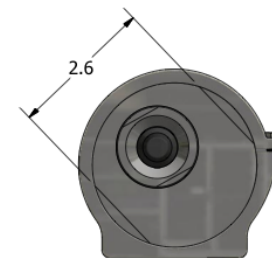
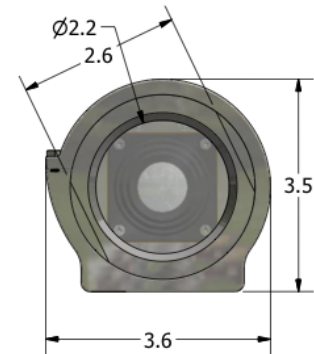

RJ45 Male IP67
CEI MV-4 Profile

Call Components Express, Inc. at 630-257-0605 for Ordering Information.

Stainless_Series- Rev A