

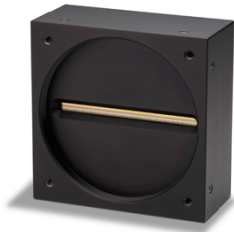

8K Trilinear Color CMOS Camera



Based on Teledyne e2v's trilinear color CMOS sensor, the new Piranha4 8k camera provides outstanding signal-to-noise for color imaging. The camera has 8k resolution with a $7.5\ \mu\text{m} \times 7.5\ \mu\text{m}$ pixel size for optimized optical design, delivering a maximum line rate of 33 kHz x 3, and a Camera Link interface.

The choice to use either an ASCII command or an advanced GenICam™ compliant interface makes the camera easier to setup, control, and integrate. Programmability includes exposure control, flat field correction, white balance, color correction, and gain settings.

The Piranha4 8k color camera is ideal for printing, PCB, electronics, film, and large format web inspection.

Key Features

- Trilinear color CMOS line scan
- 8k pixel resolution
- Line rates up to 33 kHz x 3
- Exposure control
- 100x anti-blooming
- Camera Link interface
- GenICam or ASCII command interfaces

Programmability

- Save up to eight sets of correction coefficients
- Adjustable gain and offset
- White balance and color correction
- Lens and shading correction
- Test pattern and diagnostics
- Multi-ROI output allows faster line rates

Typical Applications

- Printing inspection
- PCB inspection
- High performance document scanning
- Electronics
- Film inspection
- High throughput applications

Specifications

Resolution	8192 x 3 pixels
Line Rate	33 kHz x 3, maximum
Pixel Size	$7.5\ \mu\text{m} \times 7.5\ \mu\text{m}$
Data Format	24 bit RGB (8 x 3)
Output	Camera Link
Lens Mount	M72 x 0.75
Responsivity & QE	See graphs
Dynamic Range	56 dB
Nominal Gain Range	Up to 12, 1x to 4x
Size	80 mm (W) x 80 mm (H) x 40.1 mm (D)
Mass	295 g
Operating Temp	0 °C to +60 °C, measured at the front plate
Power	Hirose 6-pin male, +12 VDC to +24 VDC
Power Dissipation	< 6.5 W
Control & Data	Camera Link
Regulatory Compliance	CE and RoHS

Camera Models

Part Number	Resolution	Max Line Rates	Pixel Size	Output
P4-CC-08K03T-01-R	8,192 x 3 pixels	33 kHz x 3 99 kHz aggregate	$7.5\ \mu\text{m} \times 7.5\ \mu\text{m}$	RGB





Piranha4 8k Color

Trilinear RGB CMOS Camera

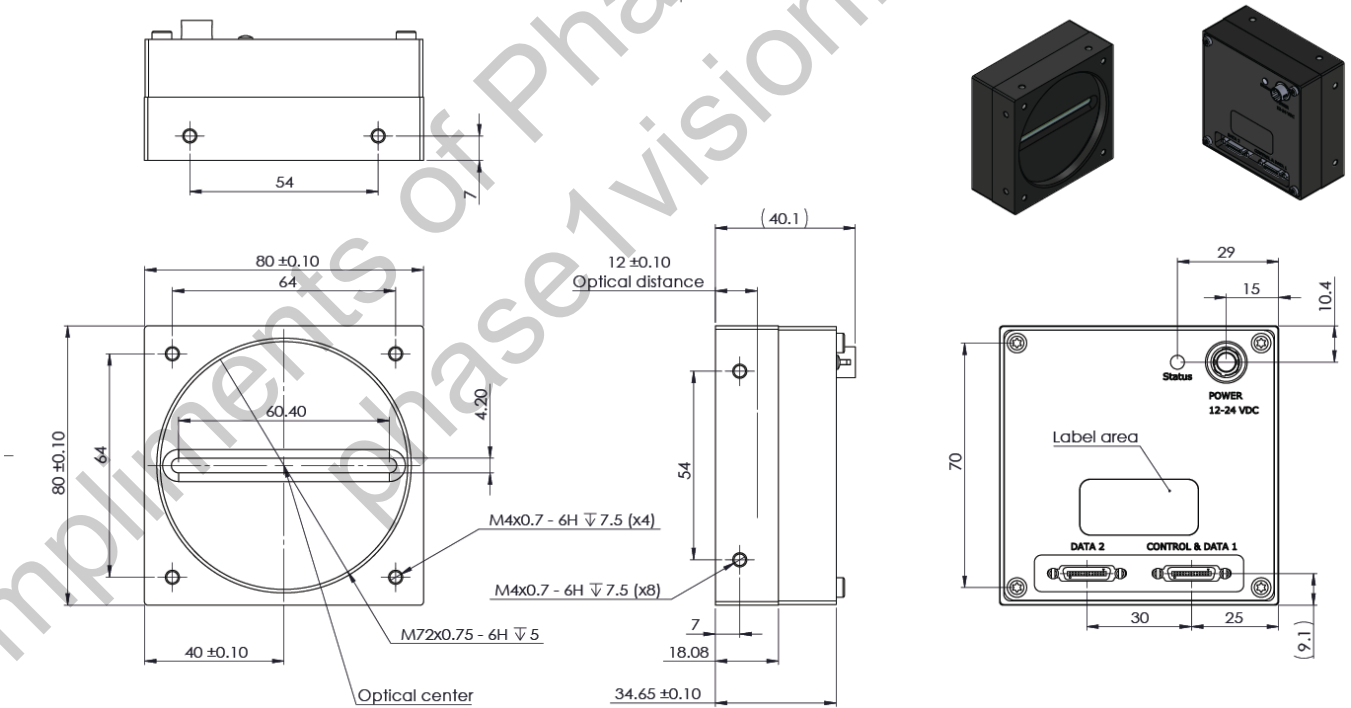
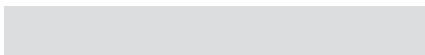
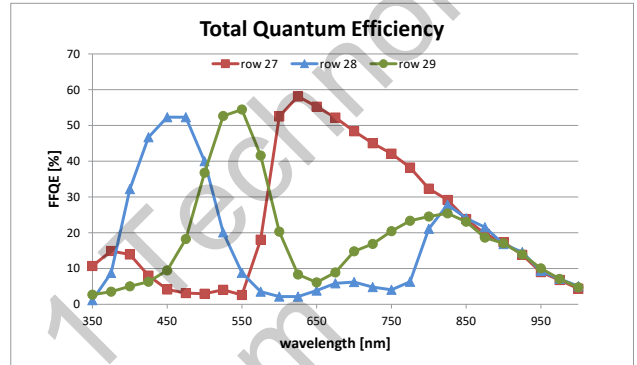
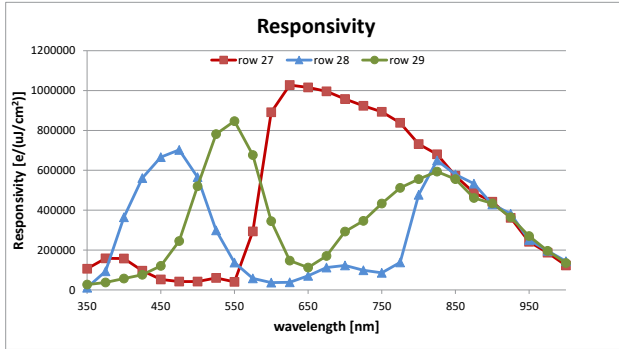

www.teledynedalsa.com

Americas
 Boston, USA
 +1 978-670-2000
 sales.americas@teledynedalsa.com

Europe
 Krailling, Germany
 +49 89-89-54-57-3-80
 sales.europe@teledynedalsa.com

Asia Pacific
 Tokyo, Japan
 +81 3-5960-6353
 sales.asia@teledynedalsa.com

Shanghai, China
 +86 21-3368-0027
 sales.asia@teledynedalsa.com

Teledyne DALSA, a business unit of Teledyne Digital Imaging Inc., has its corporate offices in Waterloo, Canada. Teledyne DALSA reserves the right to make changes at any time without notice. Teledyne DALSA © 2019. Revision number 03-070-20124-00. Revision date 21 June 2019



Part of the Teledyne Imaging Group