

Specifications for AP-1600T-PMCL

Apex Series

Specifications	AP-1600T-PMCL
Sensor	1/2.9" 3-CMOS global shutter (IMX273)
Active pixels	1456 (h) x 1088 (v) x 3 (R,G,B)
Frame rate, full frame	126.1 frames/sec. @ 8-bit
Active area	5.02 mm (h) x 3.75 mm (v) - 6.27 mm diagonal
Pixel size	3.45 μm x 3.45 μm
Pixel clock (Camera Link)	37.125 / 74.25 / 84.85 MHz
Read-out modes	Full ROI (single) 1456 (h) x 1088 (v) up to 126.1 fps H: 16 to 1456 pixels in 16 pixel steps V: 2 to 1088 lines in 2 line steps ROI (multi) Binning Up to 4 non-overlapping areas can be defined. 1X2, 2X1, 2X2
EMVA 1288 Parameters	12-bit output format
Absolute sensitivity	3.88 p (λ = 525 nm)
Maximum SNR	40.66 dB
Traditional SNR*	>60 dB (0 dB gain, 10-bit)
Video signal output	8/10/12-bits per channel† (24/30/36-bit RGB)
Video modes	Normal, Single ROI, Multi ROI, Sequencer
Gain	Manual control - master mode or individual R/G/B channels Auto gain control - off, continuous, one-push
White balance	Off, 4 presets (3200K, 5000K, 6500K, 7500K), or one-push/continuous AWB using gain or exposure time (3000K to 9000K)
Gamma/LUT	0.45 to 1.0 (9 steps) or 257-point programmable LUT
Shading correction	Flat shading, color shading
Trigger input	Camera Link, Opto In (2), Pulse Generators (4), Software, NAND Out (2), User Output (4)
Exposure modes	Timed/EPS, Trigger Width, Auto
Electronic shutter	(can be set independently for R/G/B channels) 15.26 μs to 8 sec. in 1 μs steps (8-bit) 15.26 μs to 8 sec. in 1 μs steps (10-bit)
Auto Level Control (ALC)	Shutter range from 100 μs to 13.427 ms, gain range from 0 dB to +12 dB. Tracking speeds and max. values adjustable.
Pre-processing functions	Color enhancer, edge enhancer, color space conversion (RGB to HSI, XYZ, sRGB, Adobe RGB), blemish compensation (200 px/channel)
Operating temp. (ambient)	-5°C to +45°C (20 to 80% non-condensing)
Storage temp. (ambient)	-25°C to +60°C (20 to 80% non condensing)
Vibration	3G (20 Hz to 200 Hz, XYZ directions)
Shock	50G
Regulations	CE (EN61000-6-2, EN61000-6-3) FCC Part 15 Class B, RoHS/WEEE
Power	12-pin PoCL +12V to +24V DC ± 10%. 6.0 W typical @ +12 V +12V DC ± 10%. 6.0 W typical @ +12 V
Lens mount	C-mount
Dimensions (H x W x L)	44 mm x 44 mm x 74 mm (excl. connectors)
Weight	170 g

Ordering Information	
AP-1600T-PMCL	3-CMOS prism color camera with Camera Link

*Traditional SNR is based on random noise in a single frame, where EMVA SNR measurements consider more comprehensive noise sources and variance over time.

Europe, Middle East & Africa Phone +45 4457 8888 Fax +45 4491 8880	Asia Pacific Phone +81 45 440 0154 Fax +81 45 440 0166	Americas Phone (Toll-Free) 1 800 445 5444 Phone +1 408 383 0300
---	---	--

Visit our website on www.jai.com

Dimensions

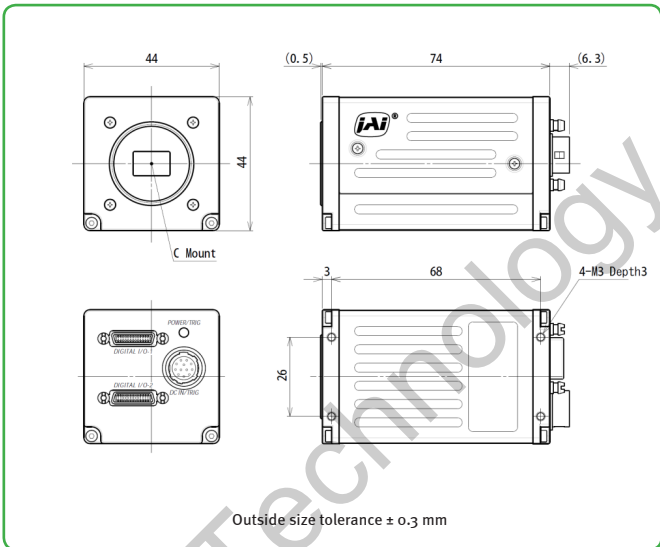

Connector pin-out

DC In / Trigger

HIROSE HR10A-10R-12PB(71)

Pin	Signal
1	Ground
2	DC in +12V to +24V
3	Opto In 2-
4	Opto In 2+
5	Opto In 1-
6	Opto In 1+
7	Opto Out 1-
8	Opto Out 1
9	TTL out 1
10	NC
11	DC in +12V to +24 V
12	Ground

Mini-CL Interface

Pin	Signal	Function	
1	26	Power	
2	15	X0-/X0+	CL Data
3	16	X1-/X1+	CL Data
4	17	X2-/X2+	CL Data
5	18	Xclk-/Xclk+	CL CLK
6	19	X3-/X3+	CL Data
7	20	SerTC-/SerTC-	Serial in
8	21	SerTFG-/SerTFG+	GND
9	22	CC1-/CC1+	Trigger*
10	23	CC2-/CC2-	Reserved
11	24	CC3-/CC3+	Not used
12	25	CC4-/CC4-	Not used
13	14	GND	

*Via Camera Link or 12-pin connector

Note: Camera Link Base configuration shown. For other configurations, refer to Camera Link specifications or operation manual.

Spectral response

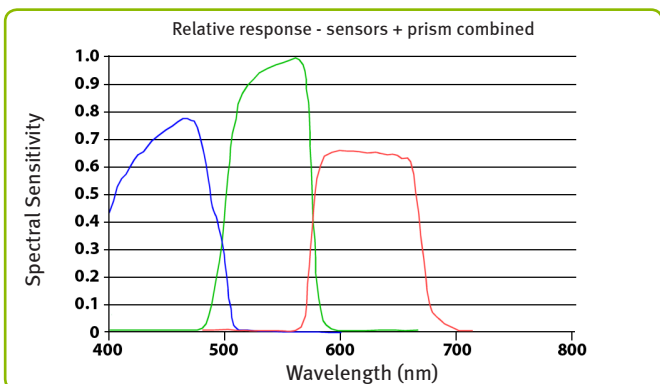

†12-bit output available in video processing bypass mode. See manual for details.

Company and product names mentioned in this datasheet are trademarks or registered trademarks of their respective owners. JAI A-S cannot be held responsible for any technical or typographical errors and reserves the right to make changes to products and documentation without prior notice.



See the possibilities