

G20Z36S-H

36x global shutter block camera

1080p 60fps HD-SDI/EX-SDI/TVI/CVBS



HD-SDI EX-SDI TVI CVBS



Features

- 1/2.3" 2MP Sony Global Shutter CMOS Image Sensor
- HD-SDI, EX-SDI Video Output (Up to 1080p)
- Camera setup by OSD Menu
- Built-in 36x lens supporting Day & Night (6.0mm ~ 216.0mm)
- Supports External trigger input and Strobe output
- Digital Slow Shutter
- Digital Noise Remove (2D+3D)
- Digital Image Stabilizer
- Defog Function

Dimensions

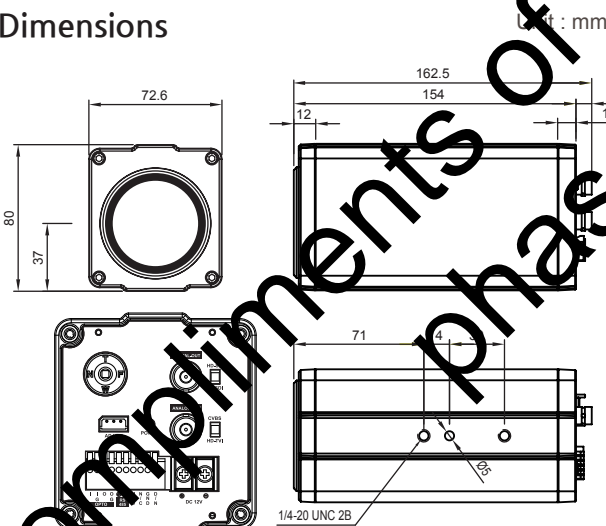

| MODEL | | G20Z36S | | |
|-------------------------|---|--------------------------|--------|--------|
| CAMERA | | | | |
| Image Sensor | 1/2.3" Sony Global Shutter CMOS Sensor | | | |
| Total Pixels | 1936(H) x 1226(V) = 2.37M pixels | | | |
| Active Pixels | 1936(H) x 1216(V) = 2.35M pixels | | | |
| Video Format | 1080p@60/50fps, 1080p@30/25fps, 720p@60/50fps, 720p@30/25fps | | | |
| Min. Illumination | Color | 0.3 lux / DSS 0.002 lux | | |
| | BW | 0.05 lux / DSS 0.002 lux | | |
| AGC Ratio | More than 50dB (AGC off) | | | |
| Video Output | HD-SDI, EX-SDI, TVI, CVBS | | | |
| LENS | | 36x | | |
| Lens Type | 36x Day & Night Zoom Lens | | | |
| Zoom Ratio | Optical 36x, Digital 32x Zoom | | | |
| Focal Length | f = 6.0 mm ~ 216.0 mm | | | |
| Aperture Ratio | F1.5 (wide) ~ F4.8 (tele) | | | |
| Angle Of View (D, H, V) | WIDE | 59.13° | 52.62° | 31.08° |
| | TELE | 2.24° | 1.95° | 1.10° |
| CAMERA FUNCTIONS | | | | |
| Camera Title | ID / Title / Zoom Ratio / System Message | | | |
| Day & Night | Auto / Day / Night / Ext-in | | | |
| BLC | Off / BLC / HLC | | | |
| ACE | 0 ~ 20 steps | | | |
| DNR | Auto / Off / Low / Middle / High | | | |
| Defog | Off / Manual / Auto | | | |
| Image Stabilization | Off / On | | | |
| Motion Detection | Off / On (3 positions) | | | |
| Privacy Mask | Off / On (8 points) | | | |
| Digital Slow Shutter | Off / 2x / 4x / 8x / 16x / 32x (/64x : 60 or 50fps mode only) | | | |
| Gain Control | 0 ~ 10 steps | | | |
| White Balance | Auto / One Push / Manual / Indoor / Outdoor | | | |
| Shutter Speed | 1/1 ~ 1/20,000 sec | | | |
| E.Zoom | Off / MAX 2x ~ 32x | | | |
| Digital Flip | Off / H / V / H&V | | | |
| GENERAL | | | | |
| Power Source | DC12V±10% | | | |
| Power Consumption | Max 550mA | | | |
| Operating Temperature | -10°C ~ +50°C / 0% ~ 90% RH | | | |
| Dimensions | 72.6(W) x 80(H) x 162.5(D) mm | | | |
| Weight | 0.82Kg (TBD) | | | |