

G20Z36S-S

Global Shutter 36x Zoom Module

HD-SDI EX-SDI CVBS



Features

- 1/2.3" Sony Global shutter CMOS sensor
- 1080p 60fps/30fps, 720p 60fps/30fps
- 36x Optical Zoom(6mm~216mm) & 32x Digital Zoom
- F1.5(wide) ~ F4.8(tele)
- Day & Night(ICR)
- Digital Noise Reduction(2D+3D)
- Digital Image Stabilization
- Privacy Mask Function
- Intelligent Motion Detection
- Defog Function
- Supports VISCA, Pelco-D/P Protocol
- Video Out : HD-SDI, EX-SDI, HD-TVI, CVBS

Dimensions

Unit : mm

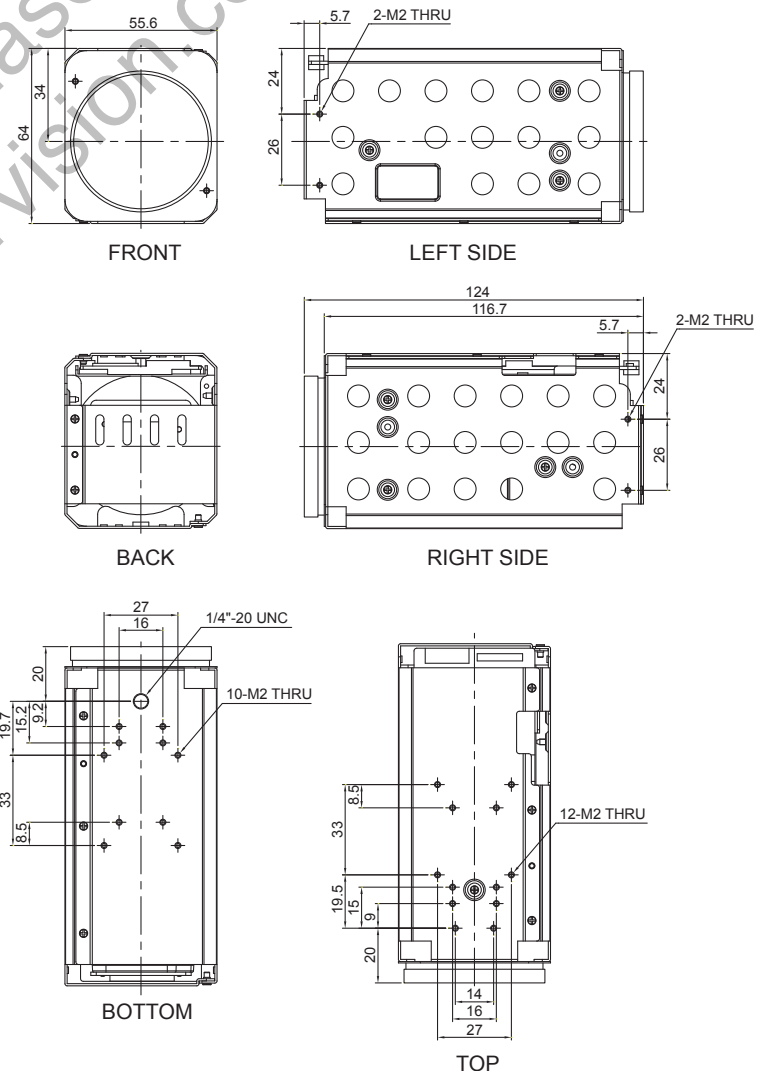

Field of View

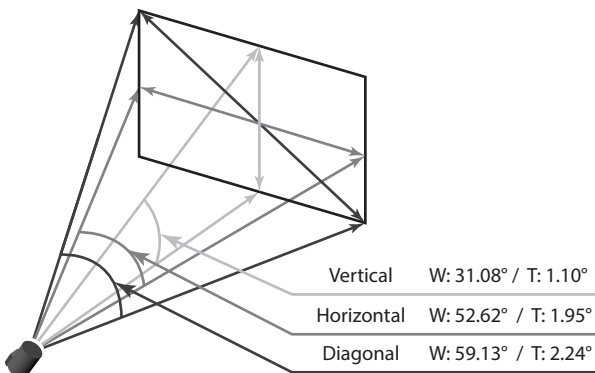

Specifications

G20Z36S-S				
Image Sensor	1/2.3" Sony CMOS Sensor			
Total Pixels	1,936(H) x 1,226(V) = 2.37M pixels			
Active Pixels	1,936(H) x 1,216(V) = 2.35M pixels			
Scanning System	Progressive Scan			
Sync. System	Internal			
Resolution	Digital : 1080p/60(50)fps, 1080p/30(25)fps, 720p/60(50)fps, 720p/30(25)fps Analog : CVBS			
Min. Illumination	Color(1/30s, 48dB) : 0.3 lux , BW(1/30s, 48dB) : 0.01 lux Color DSS(1/2s, 48dB) : 0.06 lux , BW DSS(1/2s, 48dB) : 0.002 lux			
Video Output	Digital : HD-SDI, EX-SDI Analog : HD-TVI, CVBS			
S/N Ratio	more than 50dB (AGC off)			
Lens Type	36x Day & Night Zoom Lens			
Zoom Ratio	Optical 36x, Digital 32x Zoom			
Focal Length	f = 6.0 mm ~ 216.0 mm			
Aperture Ratio	F1.5 (wide) ~ F4.8 (tele)			
Angle Of View(D, H, V)	Wide	59.13°	52.62°	31.08°
	Tele	2.24°	1.95°	1.10°
Trigger Polarity	Active Low / Active High			
Trigger Delay	0 ~ 255.9ms			
Strobe Polarity	Active Low / Active High			
Strobe Delay	Ext-Trigger : 0 ~ 255.9ms / Free run : 0 ~ (1V period - Width)ms			
Strobe Width	Ext-Trigger : 0 ~ 255.9ms / Free run : 0 ~ (1V period - Delay)ms			
Shutter Speed(Ext-trigger)	1/30(25) ~ 1/20,000 sec			
AGC(Ext-trigger)	0 ~ 10 steps			
Iris(Ext-trigger)	Close ~ F1.5			
Day&Night(Ext-trigger)	Day / Night			
AF Mode	Auto / One Push / Manual			
Min. Distance	0.1 / 1.5 / 3.0 / 5.0 / 10.0 m			
Lens Refresh	One Push / 1 ~ 10Days			
Digital Zoom	Off / MAX 2x ~ 32x			
Exposure	Auto / Iris. Priority / Shut. Priority / Manual			
Digital Slow Shutter(DSS)	Off / 2x / 4x / 8x / 16x / 32x (64x : 60 or 50fps mode only)			
Brightness	0 ~ 14 steps			
BACK LIGHT	Off / BLC / HLG			
Night Function Set	Off / On			
White Balance	Auto / One Push / Manual / Indoor / Outdoor			
DNR	Auto / Off / Low / Middle / High			
Mirror	Off / H / V / H&V			
Sharpness	0 ~ 10 steps			
Defog	Off / Manual / Auto			
Privacy Mask	Off / On (8 points)			
Motion Detection	Off / On (3 points)			
Defect Detection	Off / On			
System	NTSC / PAL			
Communication	Baud Rate : 2400 / 4800 / 9600 / 19200 / 38400 / 57600 / 115200 Protocol : VISCA / Pelco-D / Pelco- P / Update			
Language	English / Simplified Chinese / Traditional Chinese / Japanese			
Power Source	9V to 15V DC			
Power Consumption	550mA(@ 12VDC)			
Power Input	Connector			
Video Output	Connector			
Storage Temperature	-20℃ ~ +60℃ (Humidity : 0%RH ~ 90%RH)			
Operating Temperature	-10℃ ~ +50℃ (Humidity : 0%RH ~ 90%RH)			
Dimensions	55.6(W) x 64(H) x 124(D)			
Weight	416g			

Pin Assignment

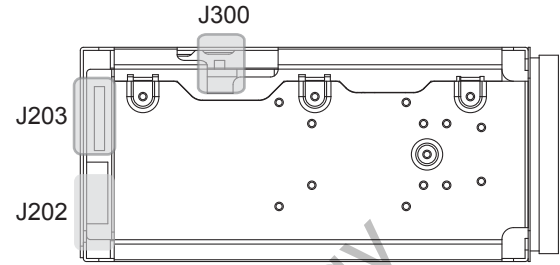

J203		J202	
1	TVI-OUT	1	RxD
2	GND	2	TxD
3	VBS-OUT	3	GND
4	GND	4	DC+12V
5	N.C	5	GND
6	N.C	6	VBS-OUT
7	N.C	7	GND
8	N.C	8	TVI-OUT
9	N.C	9	GND
10	N.C		
11	N.C		
12	N.C		
13	N.C		
14	STROBE_OUT (CMOS 3.3V)		
15	TRIG_IN (CMOS 3.3V)		
16	+5V-OUT		
17	GND		
18	GND		
19	DC+12V		
20	DC+12V		
21	DC+12V		
22	GND		
23	GPIO2		
24	GPIO1		
25	ADKEY (OSD Control)		
26	D/N-IN		
27	IR-ON		
28	MD-OUT		
29	RS-485(-)		
30	RS-485(+)		

Ref 10019HR-09(YEONHO)

J300	
-	HD-SDI/EX-SDI

Ref MMCX-R/A

Ref USL00-30L-C(KEL Cop.)