

❖ **GO-2401-PGE**  
2.35-megapixel CMOS global shutter



- *2.35-megapixel 1/1.2" CMOS imager (global shutter)*
- *Up to 32.8 fps at full resolution*
- *5.86  $\mu\text{m}$  square pixels*
- *Small size (29 x 29 x 41.5 mm, excluding lens mount)*
- *8/10/12-bit output in choice of monochrome or raw Bayer color models*
- *Exposure control from 73  $\mu\text{s}$  to 8 seconds in 1  $\mu\text{s}$  steps*
- *2X binning for increased sensitivity (monochrome only)*
- *Single and multi-ROI modes for flexible windowing and use of smaller optics*
- *Automatic Level Control (ALC) for dynamic lighting conditions*
- *Accepts power over GigE Vision interface or separate 6-pin connector*
- *C-mount lens mount*

# Specifications for GO-2401-PGE

# Go Series

Specifications	GO-2401-PGE
Sensor	1/1.2" CMOS global shutter (IMX249)
Frame rate, full frame	32.8 frames/sec. @ 8-bit
Active area	11.3 mm (h) x 7.13 mm (v), 13.4 mm diagonal
Cell size	5.86 μm (h) x 5.86 μm (v)
Active pixels	1936 (h) x 1216 (v)
Read-out modes	Full ROI (mono) 1936 (h) x 1216 (v) up to 32.8 fps H: 16 to 1920 pixels in 16 pixel steps V: 1 to 1215 lines in 1 line steps ROI (color) H: 16 to 1920 pixels in 16 pixel steps V: 2 to 1214 lines in 2 line steps Binning 1x2, 2x1, 2x2 (monochrome only)
EMVA 1288 Parameters	At 10-bit output
Absolute sensitivity (mono)	TBD p (λ = 525 nm)
Absolute sensitivity (color)	TBD p (λ = 525 nm)
Maximum SNR (mono)	45.22 dB
Maximum SNR (color)	45.26 dB
Traditional SNR*	mono >60 dB (0 dB gain) color >60 dB (0 dB gain, green,)
Video signal output	mono 8/10/12-bit monochrome† color 8/10/12-bit raw Bayer†
Gain control	Manual/auto 0 dB to +24 dB
White balance (GO-2400C)	Manual, one-push auto, or continuous (3000K to 9000K)
Gamma	0.45, 0.6, 1.0 or 256-point LUT
Synchronization	Internal
Video modes	Normal, Single ROI, Multi ROI, Sequence (Trigger & Command), Delayed Readout
Trigger input	Opto In, Pulse Generator, Software, NAND Out (2), User Output (2), Action Commands (2)
Trigger modes	EPS, Trigger Width, Sequence
Electronic shutter	
Timed exposure	73 μs to 8 sec in 1 μs steps
Auto shutter	1/32 to 1/13698 sec.
Auto Level Control (ALC)	Shutter range from 1/32 to 1/13698, gain range from 0 dB to +24 dB Tracking speeds and max values adjustable.
Pre-processing functions	Blemish compensation (256 pixels), shading
Operating temperature	-5°C to +45°C
Storage temperature	-25°C to +60°C
Humidity	20 - 80% non-condensing
Vibration	10 G (20 Hz to 200 Hz XYZ)
Shock	80 G
Regulations	CE (EN61000-6-2, EN61000-6-3), FCC Part 15 class B, RoHS, WEEE
Power	
6-pin connector PoE	12V to 24V DC ± 10%. TBD W typical @ 12V 36V to 57V DC. TBD W typical @ 48V
Lens mount	C-mount
Dimensions (H x W x L)	29 mm x 29 mm x 41.5 mm (excl. lens mount)
Weight	46 g

## Ordering Information

GO-2401M-PGE	Monochrome camera with GigE Vision
GO-2401C-PGE	Color camera with GigE Vision

\*Traditional SNR is based on random noise in a single frame, where EMVA SNR measurements consider more comprehensive noise sources and variance over time. For a more complete description, see the manual.

† 12-bit output available in IP bypass mode

## Dimensions

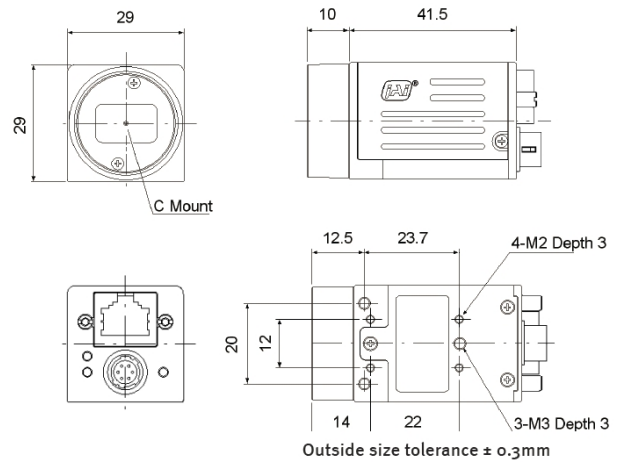

## Connector pin-out

### DC In / Trigger

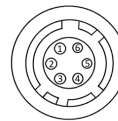

HIROSE HR-10A-7R-6PB(73)

Pin	Signal
1	+12V to +24V DC Input
2	Opto In 1
3	Opto Out 1
4	Opto Out 2
5	Opto Common
6	GND

### GigE Vision Interface

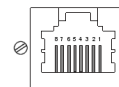

RJ-45 with locking screws

Pin	Signal
1	TRD+ (0)
2	TRD- (0)
3	TRD+ (1)
4	TRD+ (2)
5	TRD- (2)
6	TRD- (1)
7	TRD+ (3)
8	TRD- (3)

## Spectral Response

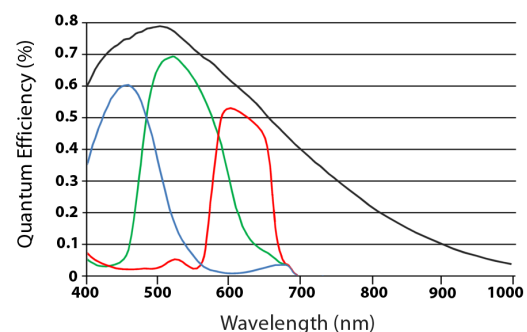

Monochrome —  
 Red — Green — Blue —  
 Note: color response includes IR-cut filter (half value 670 nm)

Company and product names mentioned in this datasheet are trademarks or registered trademarks of their respective owners. JAI AS cannot be held responsible for any technical or typographical errors and reserves the right to make changes to products and documentation without prior notification.

Europe, Middle East & Africa  
 Phone +45 4457 8888  
 Fax +45 4491 3252

Asia Pacific  
 Phone +81 45 440 0154  
 Fax +81 45 440 0166

Americas  
 Phone (Toll-Free) 1 800 445 5444  
 Phone +1 408 383 0300



Visit our web site on [www.jai.com](http://www.jai.com)

See the possibilities