

SW-2000M-CL-65

Monochrome CMOS line scan camera



- **Monochrome CMOS line scan camera with Camera Link output**
- **Large 20 μm square pixels for high line rates with less light**
- **Resolution: 2048 pixels**
- **Maximum scan rate: 65,000 lines per second**
- **Selectable sensor mode: high responsivity or high dynamic range**
- **8/10/12-bit output via Camera Link Base configuration**
- **Selectable pixel clock rate**
- **Single, dual, and triple data formats**
- **DSNU correction as factory default**
- **Flat field correction (FFC)**
- **ROI and binning modes**
- **Normal and reversed output**
- **Test pattern generator for set-up and troubleshooting**
- **Ethernet port for control and monitoring, FW updates, and download of files from camera**
- **Short ASCII commands for set-up via Camera Link or Ethernet port using the Telnet protocol**
-Windows user interface
- **JAI SDK and GenICam compliant**



Specifications for SW-2000M-CL-65

Specifications

Scanning system	CMOS line sensor with internal clock
Pixel clock	20 MHz to 85 MHz adjustable
Sensor resolution	2048 pixels
Cell size	20.0 μm (h) x 20.0 μm (v)
Imager length	40.96 mm
Line scan period	15.3 μs to 0.1 s
Line rate	10 Hz to 65 kHz
Read-out modes	Camera Link Base configuration 8, 10 or 12 bits x1 8, 10 or 12 bits x2 8 bits x3
Quantum well size	60 or 360 μe^-
Responsivity	480 DN/n/cm ² (DN as 12-bits, small well, gain = 1x, $\lambda = 625 \text{ nm}$) @ 60 kHz
Maximum SNR	55 dB (large well, EMVA 1288) @ 60 kHz
Temporal dark noise	1.9 DN (DN as 12-bits, large well, gain=1x)
Dynamic range	66 dB
Analog gain	1x, 2x, 6x or 12x
Digital gain	0.1x to 32x
Operating modes	External (external trigger/shutter), Internal (internal trigger/shutter), Mixed (external trigger, internal shutter) Pulse width control (external trigger/shutter)
Programmable exposure	2 μs to 0.1 s (internal shutter)
Camera control	Camera Link or 10/100 Mbps Ethernet CL baud rates: 9600, 19200, 38400, 57600, or 115200 bps
Lens mount	Nikon F-mount
Lens protrusion	27 mm, max.
Flange back distance	46.5 mm
Input window	1 mm BK7 glass, AR coated
Sensor alignment	$\pm 0.2 \text{ mm}$ ($\pm 0.1 \text{ mm}$ typical)
Operating temperature	+5°C to +50°C
Storage temperature	-10°C to +60°C
Humidity	5 - 80% relative, non-condensing
Vibration	3G (IEC 60068-2-6)
Shock	25G (IEC 60068-2-27)
Regulations	EMC emissions: EN 61000-6-4. EMC immunity: EN 61000-6-2. FFC part 15, subpart B
Power	12V to 26V DC, 5W, max.
Dimensions (H x W x L)	99.3 mm x 119.3 mm x 45.3 mm
Weight	620 g

Spectral Response

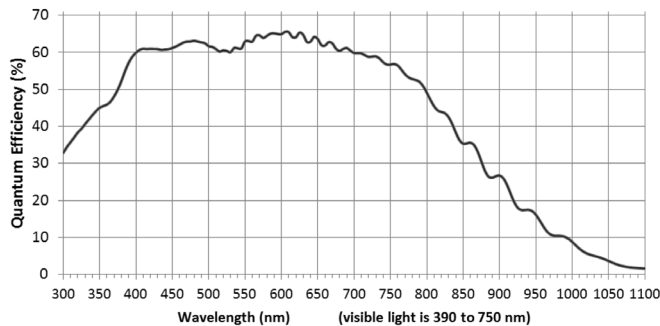

Spectral response without lens



Europe, Middle East & Africa
Phone +45 4457 8888
Fax +45 4491 8880

Asia Pacific
Phone +81 45 440 0154
Fax +81 45 440 0166

Americas
Phone (Toll-Free) 1 800 445 5444
Phone +1 408 383 0300

Visit our web site on www.jai.com

Dimensions

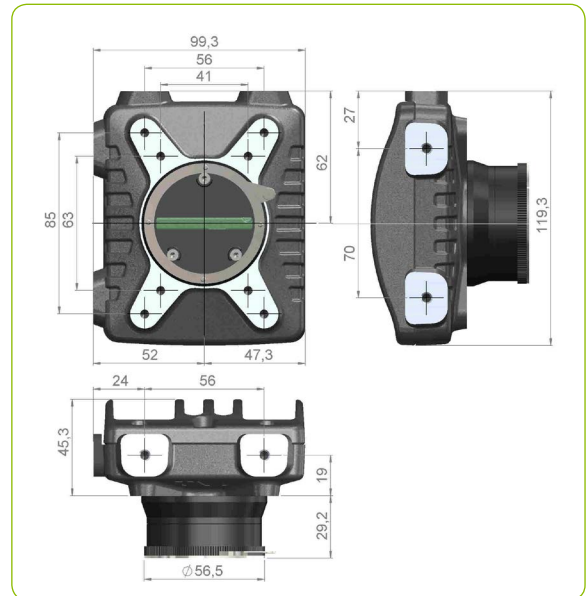

Connector pin-out

DC In

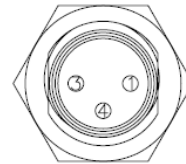

3-pin M8 male connector
(viewed looking toward camera)

Connector pin-out

Pin 1 +12V to +24V DC input
3 GND (pwr supply negative)
4 CHGND (chassis ground)

Ordering Information

SW-2000M-CL-65 Monochrome camera with Camera Link 65 kHz



See the possibilities